

# The development of visualization of the small and medium industry distribution (IKM) using a web-based geographic information system

N S Wibowo<sup>1</sup> and E Selviyanti<sup>2</sup>

<sup>1</sup>Information Technology Department, Politeknik Negeri Jember, Indonesia

<sup>2</sup>Health Department, Jember State Polytechnic, Jember, Indonesia

E-mail : nugroho@polije.ac.id

**Abstract.** The Ministry of Industry increased the IKM growth to 5-6 percent by the end of 2019. It is noted that the number of IKM in the country has increased every year. In 2015 there were 3.68 million IKM and increased to 4.41 million IKM. In 2017, the number of IKM reached 4.59 million. The SME workforce absorption has the largest proportion compared to other sectors. The percentage of labour absorption in 2016 reached 97.22 percent. In 2016, IKM in Indonesia increased by 4.5 percent, growing to 165,983 units compared to 2015 and has absorbed a workforce of 350,000 people. Data from Diskoperindag of Bondowoso Regency states that every year the number of IKMs increases by at least 5 percent, until now the number of IKM in Bondowoso has reached more than 36 thousand, an increase compared to 2013 which reached 28 thousand IKM. In order to improve and optimize the IKM in Bondowoso Regency, a system was developed that is able to assist existing IKM and new IKM that will emerge, thus providing an overview of the distribution of IKM throughout Bondowoso Regency. The IKM Geographical Information System developed is able to visualize the distribution of IKM in Bondowoso Regency well. The system has been successfully developed through testing, namely the proportion of test results of 100%, where the average value of system quality (5.6), information quality (5.4) and user satisfaction (5.35).

## 1. Introduction

Through the 2015-2019 National Medium Term Development Plan (RPJMN), the Ministry of Industry controls the creation of 20,000 new SME entrepreneurs by the end of 2019. Continuous and on target development, in the sense that it is in accordance with the potential for industrial resources and human resources in each region, we continue to strive for. This aims to continue to increase the growth of entrepreneurial growth in various regions in Indonesia.

Small and medium industries (IKM) in Indonesia support the national economy. Because, IKM as the majority sector of the industrial population in Indonesia, its activities are considered to have a positive multiplier effect to encourage equitable distribution of social welfare [1]. The Ministry of Industry increases the growth of SMIs to reach 5-6 percent by the end of 2019 where the main commodities developed are furniture, processed seafood, essential oils, coffee, non-mechanical agricultural equipment and appropriate technology, weaving, transportation equipment components and electronic and telematic products, as well as jewelry. To support this, the Ministry of Industry empowered the capacity of IKMs through strengthening institutional capacity, revitalizing machines, facilitating the



improvement of Technical Service Units (UPT), mentoring Field Extension Workers (TPL) and development and revitalization through the Special Allocation Fund (DAK).

The Ministry of Industry noted that the number of IKM business units in the country has increased every year. Where in 2013, as many as 3.43 million IKM, increased to 3.52 million IKM in 2014. Then in 2015 it was able to reach 3.68 million IKM, and in 2016 increased to 4.41 million IKM. Then in 2017, the number of IKM reached 4.59 million business units.

The absorption of labor from IKM has the largest percentage compared to other sectors. At the beginning of 2016 the labor absorption reached 97.22 percent. In 2016, IKM in Indonesia increased 4.5 percent so that it grew to 165,983 units compared to 2015 and has absorbed a workforce of 350,000 people. IKM is the dominant sector of the domestic industrial population which plays an important role as the backbone of the national economy. Amid the global economic downturn, SMIs have barely grown and their growth is relatively more stable.

Based on data from the Investment Coordinating Board (BKPM), investment realization in the manufacturing industry sector in 2014 amounted to Rp199.1 trillion, increasing to Rp222.3 trillion in 2018. Labor absorption in the industrial sector also increased, namely from 15.53 million people in 2015 to 17.9 million people in 2018 or an increase of 17.4 percent. The increase in investment, in the small industry sector, experienced an increase, from 2014 as many as 3.52 million business units to 4.49 million business units in 2017. This means that it grew to 970 thousand small industries during those four years.

The Director General of Small, Medium and Miscellaneous Industry (IKMA) of the Ministry of Industry stated that IKM is a sector that represents the total population of the manufacturing industry in Indonesia. Its contribution is up to 99 percent of all business units in the industrial sector.

The Minister of Industry said that the ministry continues to provide guidance and development to the IKM sector in the context of strengthening the national industrial structure. For this reason, the Ministry of Industry continues to encourage the growth of the IKM population in accordance with priority sectors which are also being spurred on to large-scale industries.

Bondowoso Regency is an area rich in types of natural products and handicrafts. Based on data from the Bondowoso Diskoperindag, every year the number of Small and Medium Industries (IKM) increases at least 5 percent. Currently, the number of IKM in Bondowoso reaches more than 36 thousand. This figure is an increase compared to 2013 which reached 28 thousand IKM. The SE2016 registration results show that the number of businesses / companies according to business fields is dominated by 3 categories of business fields, first large and retail trade as many as 42,946 businesses / companies (39.90 percent), secondly processing industries 37,065 businesses / companies (34.44 percent) and third. provision of accommodation and provision of food and drink for 7,552 businesses / companies (7.02 percent) of all businesses / companies in Bondowoso.

Members of Commission VI DPR RI said that IKM is one of the pillars of national development by utilizing the ability of resources to realize national development in the independent economic field. According to him, advanced industrial development is the driving factor for the economy which is supported by strong resource capabilities. Through strengthening of an independent and competitive industrial structure. Therefore, IKM must be optimized and encouraged to continue to be empowered in all regions of Indonesia, especially in Bondowoso Regency.

In order to improve and optimize the IKM in Bondowoso Regency, it is necessary to develop a system that is able to accommodate existing IKM and new IKM that will emerge, so as to provide an overview of the distribution of IKM in all Bondowoso Regency. The system to be developed is able to visualize the distribution of IKM KA in Bondowoso Regency properly. The use of Geographical Information Systems (GIS) is because it can visualize the distribution well, compared to using data tables [2]. GIS is used as a distribution visualization medium as in research [2] [4] [5] [6] [7] [8]. This study aims to map small and medium industries (IKM) using a web-based Geographic Information System (GIS) in Bondowoso district.

Geographical Information Systems can be used as the main interactive tool regarding the concepts of location, space, population, and geographic elements on the earth's surface. Geographical Information

Systems can provide a comprehensive picture of a spatial related problem where all special entities involved can be visualized to provide information both implied and express. GIS is a useful tool for collecting, retrieving desired data and displaying spatial data originating from world realities. This research aims to The Development of Visualization of The Small and Medium Industry Distribution (IKM) Using A Web-Based Geographic Information System.

## 2. Material and methods

The method in this study refers to the Water Fall Methodology as shown in Figure 1. The stage in this research is a field study which in this case is to extract information from the main source, namely the Office of Cooperatives, Industry and Trade (Diskoperindag) of Bondowoso Regency. The next stage is to formulate the problem. As stated in the previous chapter, the main problem that exists is the number of IKMs that have been established, but there is no media or platform that is able to accommodate business activists to market their products. Apart from that, from the government side, the main problem faced is the difficulty in the process of data collection and information gathering related to the IKM itself. Then determine the purpose of carrying out this research activity, namely developing a web-based application, namely a mapping application for Small and Medium-sized Industries (IKM) in the form of a web-based Geographical Information System to support the improvement of the people's economy in Bondowoso Regency.

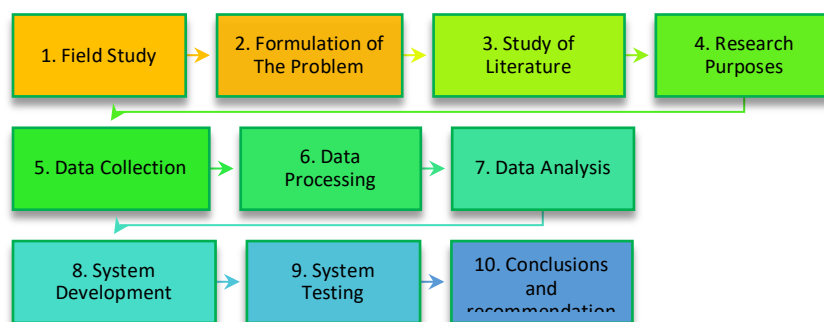

**Figure 1.** Research Methods

The next stage is literature study and the formulation of objectives to draw a common thread in the form of a solution. The solution offered in this research is to create a Small and Medium Industry (IKM) mapping application in the form of a web-based Geographical Information System to support the improvement of the people's economy in Bondowoso Regency. The next step is data collection. After the IKM data is obtained completely, both pre-existing data and additional data which the user can input directly. Next, after the data is collected properly, the data is processed and used as system variables. Next is an analysis of the previously processed data. This data is synchronized with the spatial map data of Bondowoso Regency. Subsequently carried out with application development, the development of this application involves the Office of

Cooperatives, Industry and Trade (Diskoperindag) of Bondowoso Regency. The involvement of partners in the development process aims to produce research products that are not only novelty but can actually solve partner problems. At this stage, an evaluation process is also carried out related to the performance of the information system that has been made. After the system is created and developed, the next step is to test the system that has been created. In this case the system will be tested using black box testing or white box testing. This test is carried out logically and functionally and ensures that all parts have been tested so that the resulting output is as desired. The last stage is to draw conclusions and future suggestions so that the information system can be even more useful.

### 3. Result and discussion

This study uses Water Fall Methodology because this method is in accordance with the cases handled by the study. This software development method is a method that allows the manufacture of systems to be carried out in a structured and systematic manner (sequentially) according to the existing development cycle. The waterfall method requires that every specification, requirements and system objectives be defined in detail at the initial stage (requirements & design) before entering the process (implementation). This study aims to classify IKM in Bondowoso Regency for each district. An overview of the system is shown in Figure 2.

In Figure 2, there are 3 entities, namely the diskoperindag entity as admin in entering the IKM data, then looking at the completed Geographical Information System data. The IKM entity as a user can input investment value data, production value data, employee number data, and can view Geographic Information System data. Community entities to view Geographical Information System data that already exists in Bondowoso Regency.

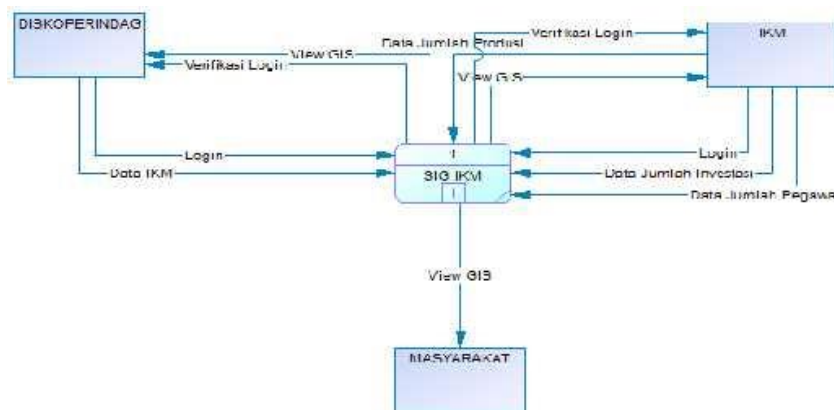

Figure 2. Context Diagram

Research conducted in an effort to improve the quality of IKM in Bondowoso Regency will produce output in the form of an IKM geographic information system implemented on a website base. The important features contained in this application are: the login menu to register for users, the administrative menu, namely the dashboard menu which is useful for Diskoperindag officers to validate IKM data, monitor and view reports on IKM developments, the news menu which contains from the latest related news as well as a marketing strategy for IKM in Bondowoso, and the last is a dashboard for IKM players to input their business information data and view reports related to sales data, turnover, and number of products. This information system is expected to make it easier for the government to monitor and assist in the process of collecting data on IKM in Bondowoso. So that the long-term goal, it is hoped that the vision of Diskoperindag is the realization of cooperatives and IKM, quality, independent, resilient and competitive industry and trade can be realized in the future.

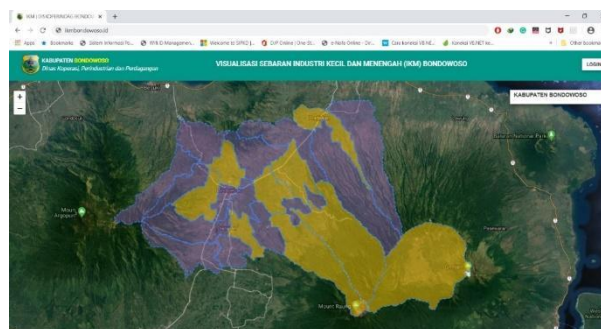

Figure 3. Small and Medium Industry Geographical Information System

Figure 3 shows the results of the development of the visualization of the distribution of Small and Medium Industries (IKM) using a web-based Geographic Information System. This web-based application was developed using the PHP programming language and the MySQL database. A Code Igniter (CI) framework in the PHP programming language is used in developing this geographic information system. The Code Igniter framework is used as a framework consisting of a set of folders containing php files that provide class libraries, helpers, plugins and others in the development of this geographic information system.

After the researchers succeeded in developing the IKM Geographical Information System, the research was continued by conducting public application tests. This test covers three aspects, namely System Quality, Information Quality and User Satisfaction. Each indicator uses the Linkert scale (5). The test results are shown in Table 1. Where it can be seen that the average value of 100 respondents for System Quality, Information Quality and User Satisfaction is 4.63, 4.71 and 4.65.

<b>Aspects</b>	<b>Result</b>
System Quality	4.63
Information Quality	4.71
User Satisfaction	4.65

#### **4. Conclusion**

Based on data from the Bondowoso Diskoperindag, every year the number of Small and Medium Industries (IKM) increases at least 5 percent. Currently, the number of IKM in Bondowoso reaches more than 36 thousand. This figure is an increase compared to 2013 which reached 28 thousand IKM. The SE2016 registration results show that the number of businesses / companies according to business fields is dominated by 3 categories of business fields, first large and retail trade totaling 42,946 businesses / companies (39.90 percent), secondly processing industries 37,065 businesses / companies (34.44 percent) and third. provision of accommodation and provision of food and drink for 7,552 businesses / companies (7.02 percent) of all businesses / companies in Bondowoso. IKM is one of the pillars of national development by utilizing the ability of resources to realize national development in the independent economic field. Advanced industrial development is a driving force for the economy which is supported by the ability of resilient resources through the strengthening of an independent and competitive industrial structure. Therefore, IKM must be optimized and encouraged to continue to be empowered in all regions of Indonesia, especially in Bondowoso Regency. Based on the test results using the Black Box Testing method, it shows 100% results, so the results of this test can be concluded that the system has developed well. In addition, this system is also well received by users, this is indicated by a questionnaire (100 respondents) which shows the numbers for System Quality, Information Quality and User Satisfaction 4.63, 4.71 and 4.65. The web-based Geographical Information System for the Distribution of Small and Medium Industries (IKM) developed in this study facilitates related agencies, in this case the Industry and Trade Office of Bondowoso Regency in obtaining more in-depth information regarding the location, number of jobs, data on investment value, total production, and quantity. IKM, the existing data center, and the distribution and mapping of the development of the IKM itself. So that the hope of this research, IKM in Bondowoso Regency can be developed further, in accordance with the service objectives.

#### **Acknowledgment**

The suggestion that the writer can convey is for the further development of an Artificial Intelligence (AI) in the web-based Geographical Information System for the Distribution of Small and Medium Industries (IKM) in Bondowoso Regency. The author also expresses his gratitude for the financial support from the Jember State Polytechnic, so that this research can be completed properly.



## References

- [1] V. Mahrizal, "Industri Kecil dan Menengah jadi Tulang Punggung Ekonomi Nasional," 14 November 2018. [Online]. Available: <https://jogja.tribunnews.com/2018/11/14/industri-kecil-dan-menengah-jadi-tulang-punggung-ekonomi-nasional>.
- [2] C. L. G. Z. S. & C. J. Cao, 2012. Research On The Environmental Impact Factors of Hand-Foot-Mouth Disease in Shenzhen, China using RS and GIS Technologies.
- [3] A. & H. A. Founoun 2019. Evaluation of the concept of the smart city through local regulation and the importance of local initiative, 2018 IEEE International Smart Cities Conference, ISC2 2018, 1–6. <https://doi.org/10.1109/ISC2.2018.8656933>
- [4] A. V. C. D. & C. A. Vitianingsih, 2017. Analysis and Design of Web-Geographic Information System for Tropical Diseases-Prone Areas: A Case Study of East Java Province, Indonesia., In 2017 4th International Conference on Information Techn,
- [5] N. & G. A. Guizani, 2014. Modeling and Evaluation of Disease Spread Behaviors., 2014 International Wireless Communications and Mobile Computing Conference (IWCMC), 996–1003. <https://doi.org/10.1109/IWCMC.2014.6906491>,
- [6] Q. & Z. S. Cheng, 2002. Fuzzy Weights of Evidence Method Implemented in GeoDAS GIS for Information Extraction and Integration for Prediction of Point Events., Symposium, 2002. IGARSS'02. 2002 IEEE ..., 00(C), 2933–2935. Retrieved from <http://iee>,
- [7] Z. A. & M. M. H. Latif, 2015. Mapping of Dengue Outbreak Distribution Using Spatial Statistics and Geographical Information System., In 2nd International Conf on Information Science and Security (pp. 1–5).,
- [8] I. S. S. E. G. M. & S. V. Klyuzhin, 2016. Feasibility of Using Geometric Descriptors of Tracer Distribution for Disease Assessment., In 2014 IEEE Nuclear Science Symposium and Medical Imaging Conference, NSS/MIC 2014 (pp. 1–5). ,

Reproduced with permission of copyright owner. Further reproduction prohibited without permission.